

# FastPac™ Briquetter

Mayfran!  
it!



FastPac Briquetter



## Maximize the value of ferrous and non-ferrous chips and turnings.

The Mayfran FastPac™ Briquetting System compresses wet metal chips, fines, and sludge into high density, compact briquettes. FastPac maximizes the value of your steel, aluminum, brass or other metal scrap by squeezing the material up to 98% dry. FastPac is designed to produce briquettes faster with its continuous feed system that discharges a briquette while another one is quickly formed.

*FastPac offers these advantages:*

- Measure your scrap output into dense briquettes that can be weighed before they are sent to your scrap hauler.
- Maximize the value of chips and turnings.
- Recover valuable coolants and oils.
- Reduce space for storage of scrap.
- Provide a cleaner work environment.



P.O. Box 43038  
Cleveland, OH 44143-0038  
Internet: [www.mayfran.com](http://www.mayfran.com)

Tel: (440) 461-4100  
Fax: (440) 461-0147  
E-mail: [info@mayfran.com](mailto:info@mayfran.com)

FastPac is a trademark of Mayfran International

© Mayfran 2001

# SPECIFICATIONS

Mayfran  
it!

## How FastPac Makes Briquettes:

The charging screw (2) feeds the material which is stored in the hopper (1) to the pre-charger. The running time of the screw is calculated by a PLC control unit.

After termination of filling by the screw the pre-charger (3) pre-compresses the material in the pre-charger chamber (4).

The main press piston (6) pushes the pre-compressed material into one of the two press chambers in the die (5) and compresses the material into a dense block. During the process the ejectors, which are fixed parallel to the main press piston, push out the ready briquette from the second press chamber through ejector holes in the front plate.

The pre-charger moves upward again. Then the feeding screw continues with the next charge.

The pressing cylinder (7) moves back to its end position. The press mold changes (5) and the run continues.

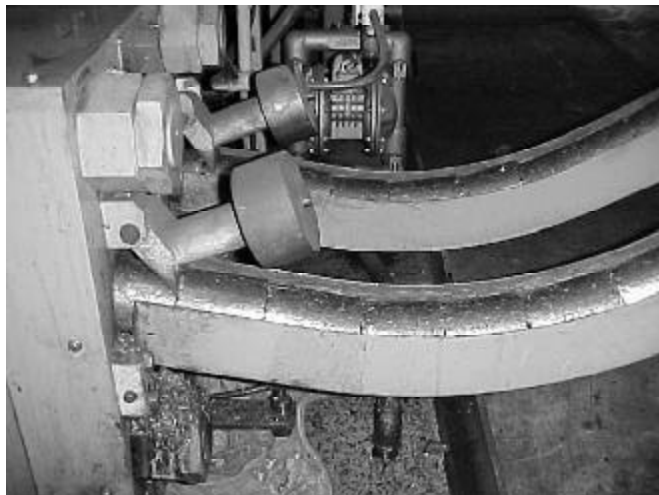
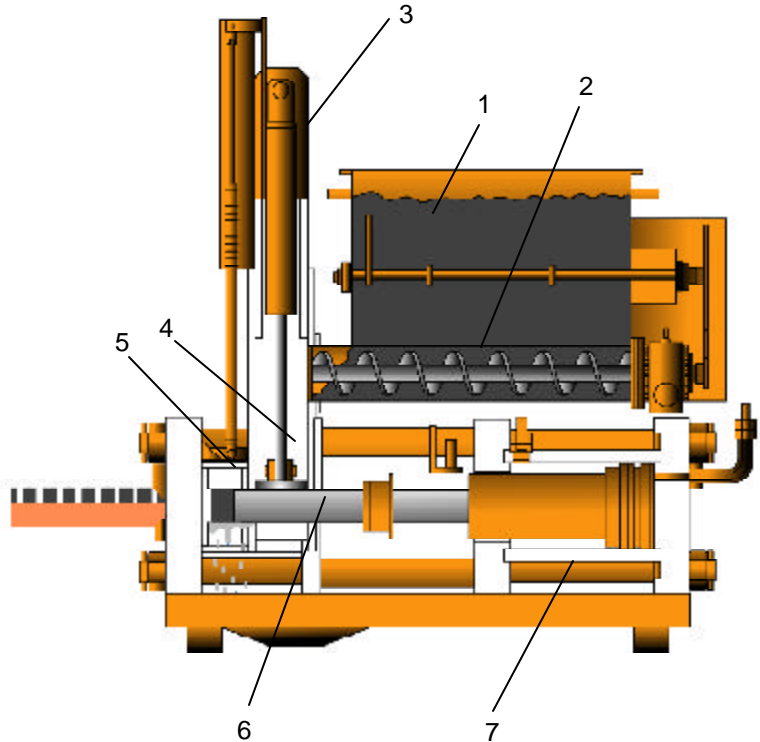

FastPac Type RB 15/3000/80 with dual discharge for aluminum briquettes.



Pump in the coolant tray under the unit transfers coolant and oils retrieved in the briquetting process.