

# Remote Downdraft Bench

**RDB-2000 and RDB-3000**

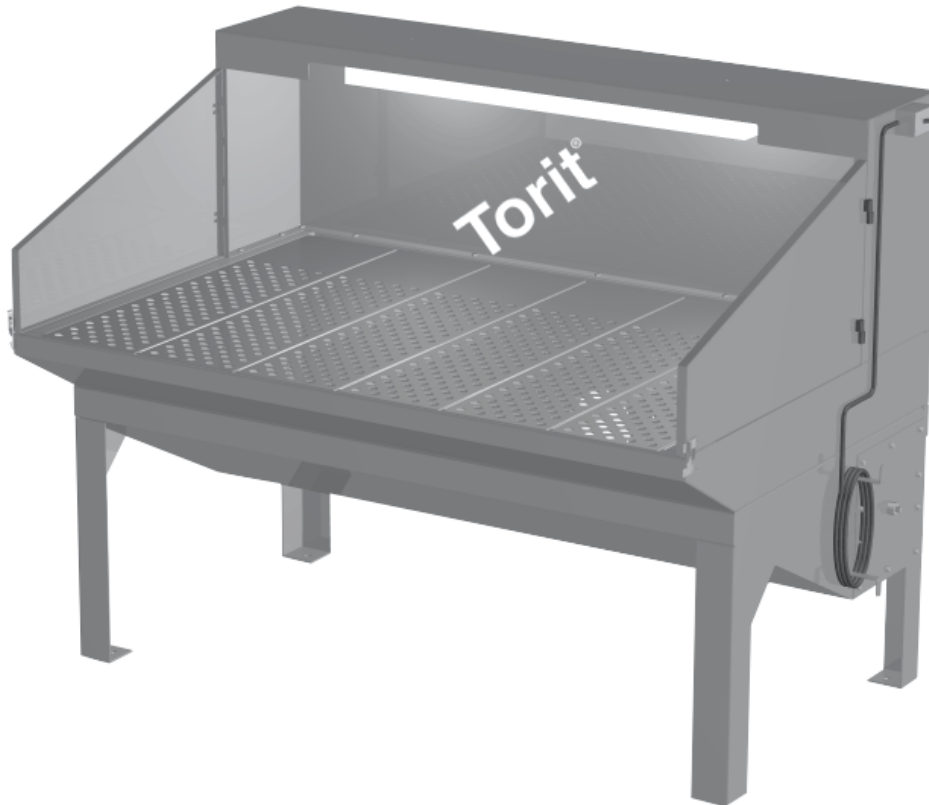

**Model RDB-3000**

- Productivity increases and morale improves by providing a cleaner working environment.
- Helps meet OSHA Clean Air Standards.
- Ergonomically designed for operator comfort.
- Hinged side-wing panels for longer than normal workpieces.
- Suitable for buffing, grinding, polishing, and welding operations.
- Ideal for multiple workers.
- Heavy-duty, 12-gauge galvanized channels with 7/8" holes.

# Torit Remote Downdraft Bench

## Equipment Options

- Scratch-resistant work surfaces
- Plasma/heavy-plate work surface
- Easy Duct™ to ease installation
- Integration to other Torit Air Filtration Systems

## Specifications

Model	Dimensions (in)					Outlet Diameter in	Shipping Weight lbs	Max Load per sq ft
	A	B	C	D	E			
<b>RDB-2000</b>	38.0	63.0	52.0	37.1	47.0	8, 10, 12	411	75 lbs
<b>RDB-3000</b>	38.0	63.0	78.0	37.1	73.0	10, 12	550	75 lbs

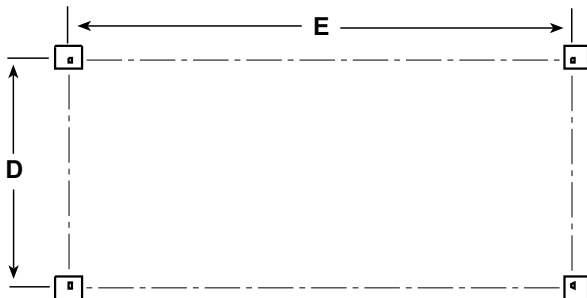
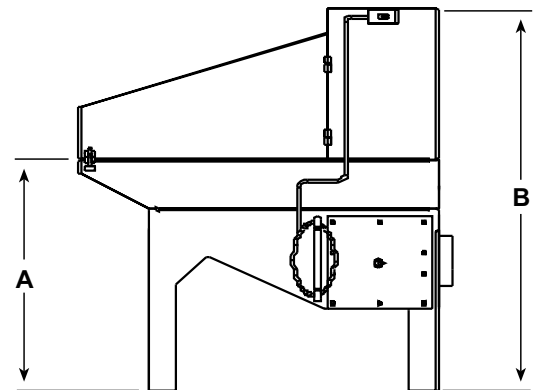
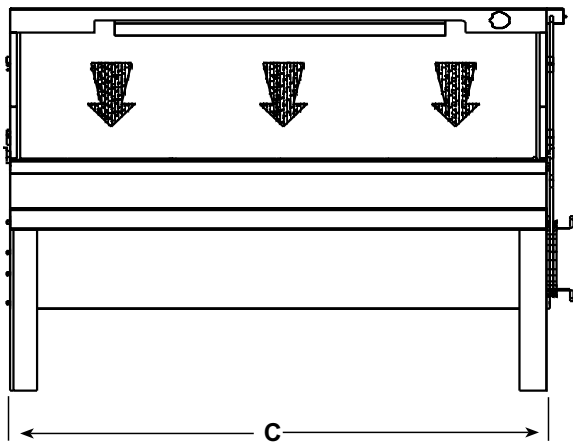

Information contained in this document is subject to change without notice.



Donaldson Company, Inc.  
 Dust Collection Group  
 P.O. Box 1299  
 Minneapolis, MN 55440  
 800-365-1331  
 www.torit.com  
 e-mail: dustmktg@mail.donaldson.com

© 2001 Donaldson Co., Inc.  
 Printed in U.S.A.  
 Printed on Recycled Paper

Form RDB (04/01)